



FABRIC GIFTS

FOR ALL OCCASIONS

Making gifts from fabric is creative and rewarding. By using your creative skills, you can turn fabric scraps and remnants into useful, attractive gifts at a price that won't strain your budget. When you make gifts yourself, you can select colors, fabrics, and combinations that reflect the personality and taste of the recipient.

To make creative gifts, all you need is a place to work, some time, and imagination. Some projects may require simple sewing skills, but you can make many projects by using glue, a staple gun, or fusible webbing. If you have spare time, select a more detailed project. If your time is limited, there are many quick and easy projects from which to choose.

This publication contains ideas to get you started. Adapt

and personalize them to fit your needs. For more ideas, check with your local library or county home economics Extension agent.

Start with the Basics

Careful planning will help you get the best results from your time and money. The following tips will help you make planning and shopping decisions.

- Shop for ideas. When you see something that appeals to you, study it carefully. Does it fill a decorative or useful purpose? How hard would it be to make? What design factors do you particularly like? What colors are used? How does one pattern complement and blend with another? What mood is created by mixing and matching the various colors and patterns?

BED AND BATH BATH AND HAND TOWEL TRIM

Use decorative braid, lace, ribbon, or appliques to give your bathroom a coordinated look. Select machine-washable trims to match or complement the window curtains, shower curtain, or other decorative features in the room. Then stitch rows of trim along one or both ends of towels.

To do this, pin the trimmings to the towels, folding under 1/2 inch at each end. Topstitch or use a small zigzag stitch around all edges (see Figure 1). Be careful not to stretch the towels or trimmings. Try combining different colors and textures for special effects.

Figure 1

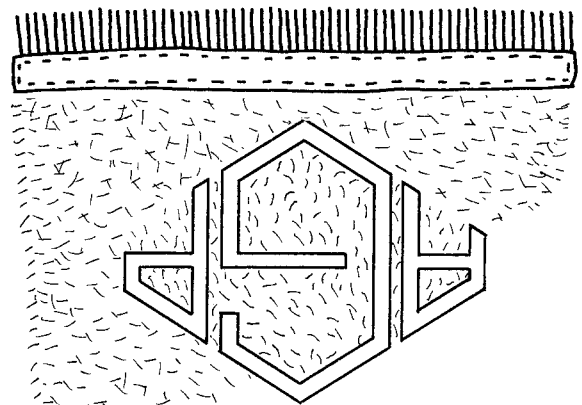
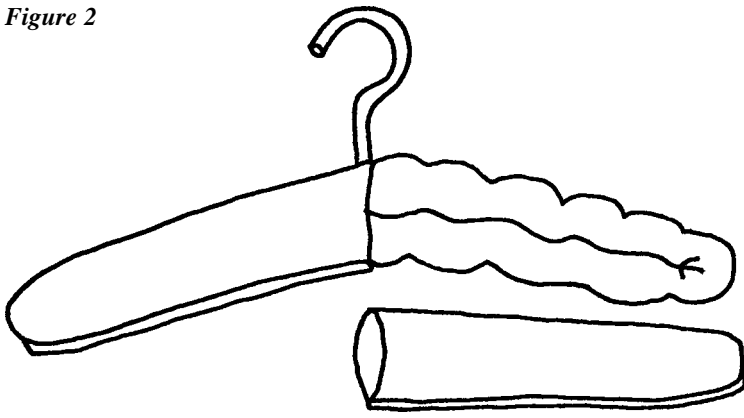

Figure 2



- Be creative! You're only limited by your imagination. For help on getting started, don't forget the many instructional books, leaflets, and patterns available. Don't be afraid to experiment. Try original designs or adapt designs from coloring books or other resources.
- Plan your project carefully. Consider your skills as well as the equipment, supplies, and the type and amount of fabric you will need. Purchase all of the fabric needed to complete a project at one time.
- Consider the likes, dislikes, and needs of the person for whom you're making the gift.
- What is your budget? What price range are you considering? Determining your budget limitations helps sort out some choices immediately.

Fabric Considerations

Depending on the project and the desired finished appearance, you can use almost any fabric. When selecting fabrics for your projects, consider:

- Is the item functional or decorative? Will it receive hard use, such as a place mat, or will it be a decorative accent, such as a picture frame? The fabric selected should be appropriate for the intended use.
- How often will the item need to be cleaned? What method of cleaning is recommended?
- How will the fabric be handled during construction? Will it be sewn, fused, or stapled? Flat, quilted, or gathered? Is the fabric easy to work with? The answers to these questions will help determine the type fabric to select.

PADDED COAT HANGER

Make a padded coat hanger by wrapping cotton or polyester batting around the arms of the hanger to a depth of $\frac{3}{4}$ inch. Anchor the ends by hand stitching. Spread decorative fabric out on a flat surface. Place the hanger on the covering fabric's bias grain and trace around one arm. Allowing an extra 1 inch around all sides, cut four pieces on the bias grain. With right sides together, stitch two arm cases, leaving the center edges open (see Figure 2). Trim seams and turn the cases right side out. Slip the cases over both arms of the hanger, overlapping them at the center. Turn raw edges under and blindstitch together around the center of the hanger. Trim with ribbon at the center.

Other bed and bath ideas include:

- Closet accessories
- Lingerie bags
- Covered storage boxes
- Lined jewelry boxes
- Shoe bags

DECORATIVE ACCENTS

FOLDERS AND BOOKS

This easy project is an attractive way to dress up an ordinary scrapbook or photo album. The following directions are for a scrapbook with removable covers.

Remove the front and back covers for ease in working. Press fabric, then measure and cut two rectangles of fabric that are 4 inches wider and 4 inches longer than the covers. Measure and cut with pinking shears two rectangles of fabric that are 1 inch narrower and 1 inch shorter than the scrapbook covers.

Figure 3

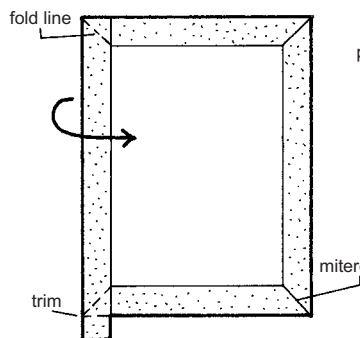
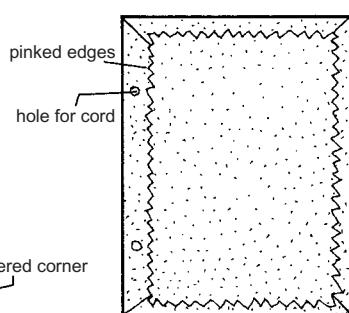

Figure 4



- Choose the weight of the fabric depending on the project and the method of construction or application. You can use medium-weight fabrics for most projects.
- Fiber content, weave, and fabric finishes affect the serviceability of the fabric, particularly abrasion resistance and colorfastness. They also determine the care requirements for the fabric.
- A variety of fabric textures adds interest to a design. Select the textures to fit both the purpose and placement of the gift.
- Color makes a great impact. Fabric is an easy way to introduce color. You can use color in many different ways and combinations. It's easy to change, too. Coordinate colors to fit the use and where the gift will be placed.
- It is difficult to determine the color performance of fabrics, but, in general, better performance can be expected from fabrics with thorough color penetration or woven-in color designs rather than those with printed-on designs. Check, too, for crocking, or color loss from rubbing or abrasion.

- Patterns available include prints, stripes, checks, and plaids. If using a patterned fabric, look at a large piece to get the full effect. Look at the overall effect rather than the individual colors. The blending of colors in a pattern can create an entirely different look, especially in fabric that is gathered or pleated. If the finished item will have gathers or pleats, fold or bunch up the fabric and then stand back to look at the overall effect. Check to be sure that the size of pattern and width of fabric are appropriate for the purpose. If you are working on a large project, it's often better to select a random design, a small all-over print, or a stripe.

Figure 5

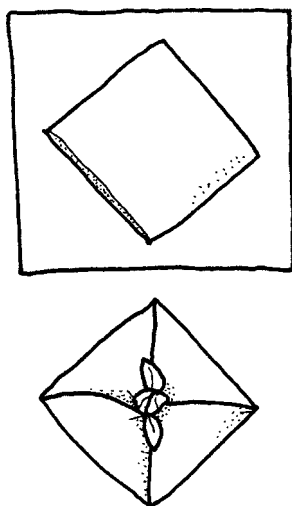

Pour glue into a disposable container and dilute with water until it spreads evenly with a paintbrush (approximately two parts glue to one part water). Working with one side of the album at a time, brush diluted glue onto the outside of the cover. Center one large piece of fabric over the cover, right side up, and smooth in place. Wrap fabric around to the inside of the cover and glue in place, mitering corners and trimming excess fabric (see Figure 3).

Now brush diluted glue onto the inside of the cover. Center one of the smaller pieces of fabric, right side up, and smooth in place. This covers the raw edges of the wrapped fabric. Repeat with remaining cover and fabric. Place a heavy weight on top of each completed cover and allow to dry thoroughly.

Using a one-hole punch or other sharp object, finish the covers by piercing the front and back covers for cord; reassemble the scrapbook (see Figure 4).

TIE PILLOWS

This fast decorating idea requires minimal sewing — just finish the raw edges of a square of fabric. A 36-inch square is large enough to cover a small, 10- to 12-inch square pillow; for larger pillows, try a 45- to 54-inch fabric square.

Place the square pillow diagonally in the middle of the fabric square. Fold the fabric corners up, and tie them in the center of the pillow (see Figure 5).

Other ideas for decorative accents:

- Fabric picture frames
- Decorated pillows
- Desk accessories
- Fabric gift sacks
- Holiday decorations
 - tree skirt
 - Christmas tree ornaments

KITCHEN/DINING ROOM

THREE-SIDED TEA COZY

This is a charming and practical accessory for keeping tea or any other beverage hot. You will need medium-weight decorative fabric, polyester batting or fleece, lightweight fabric for the backing (inside lining), decorative binding, and basic sewing supplies.

To make a paper pattern for the tea cozy, first measure the circumference of your teapot. Be sure to include the spout and handle in this measurement. Add an extra 7 to 8 inches for seam allowances and ease. Now divide this total by three. This will give you the basic width needed for your pattern (see Figure 6, points a to b). Make the cozy whatever height desired (points c to d) by drawing a triangular top similar to the illustration. Using this paper pattern as a guide, cut three shapes from the outside decorative fabric. Using the same pattern, cut three shapes from both the polyester batting or fleece and the lightweight backing fabric.

Assemble the inner cozy first by matching the polyester batting and lining fabric in pairs. Handle each of the pairs as one piece of fabric. Place right sides of lining together and sew a 5/8-inch seam from the bottom edge to the top point. Finish by sewing the other two sides of the cozy from the bottom edge to the top point.

Now assemble the outer layer of the cozy. To do this, place the wrong sides together and enclose the raw edges with seam binding from the bottom edge to the top point. Finish by tying the ends of the binding into a loop at the top of the cozy (see Figure 7). Slip this outer cozy over the inner cozy and enclose all the bottom raw edges in the binding to finish.

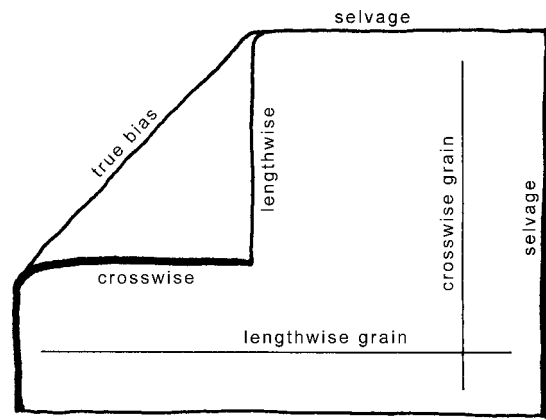

Working with a large, strongly defined repeat pattern is tricky.

- Avoid off-grain prints. If cut off-grain to match the pattern, the fabric will tend to twist and pull out of shape. If cut on-grain, the pattern will not be straight (see above).
- Plan fabric placement. For some projects it's best not to pre-trim fabric to the exact size you want. When using patterned fabric on a large area, allow at least two extra inches at the top, bottom, and sides for pattern alignment.
- Remember, haste makes waste. No matter what project you are planning or how often you sew, take time to carefully think through each project before you start. Then take your time and be patient for the best, most professional results.

Helpful Hints

You will discover your own helpful, timesaving hints as you work with fabric projects. Some hints are given below. Add others to the list as you discover them.

- Unless you are making a project that will be laundered often, such as table linens, you probably will not need to preshrink the fabric. Simply use as is for extra crispness. If fabric is soiled or needs to be preshrunk because of use or fit, launder and then use spray starch when ironing to restore its crispness.
- If using glue, work with a damp white cloth or towel. Clean off glue smudges as you work to save time later.

Figure 6

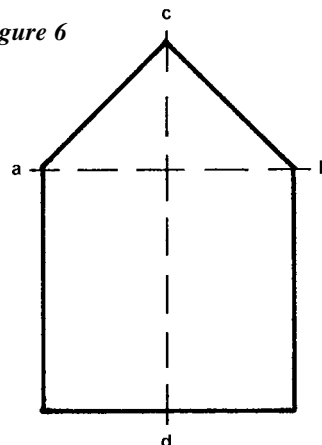

Figure 7

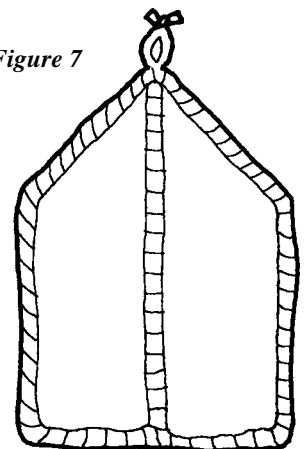
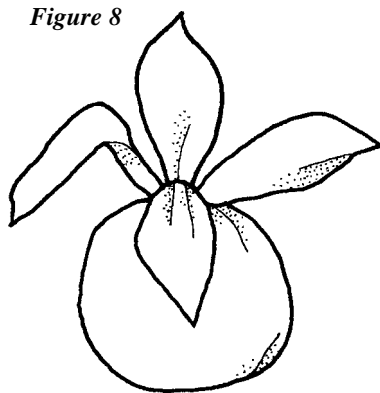

Figure 8



• When gluing fabric onto another surface, start with a clean surface in a light or dark color, depending on the color and weave of your fabric. A surface may show through a light-colored or loosely woven fabric, and a dirty surface will soil the fabric.

• If using a staple gun, paint the staples before using (while they are still glued together in stick form). A quick coat of spray paint in the color nearest the background color of the fabric will hide them after they are stapled into the fabric.

Tools and Supplies

The success of any job depends on your choice of supplies. Having the right tools makes your work easier, quicker, and more enjoyable. When using a commercial product, be sure to carefully read and follow manufacturer's directions. Always test a product on a scrap of the fabric you're using. For example, test marking pens for bleeding and ease of ink removal.

Here are some tools and supplies that might make your work easier. Look for them in the notions department of fabric stores, specialty catalogues, and craft stores.

Fusibles/Pressing Sheets

Select a fusible material compatible to both the fabric and its intended use. Look for:

- Fusibles with peel-off backings that turn any fabric into a fusible fabric. Use for making appliques and patches that are like ready-made.
- Reusable pressing sheets with a non-stick surface that you put over fabric and fusible web and press to make iron-on appliques.
- Fusible web to put between two layers of fabric to hold them together without stitching.

Figure 9

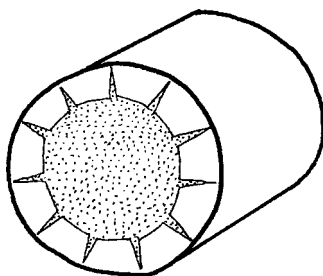

Other kitchen/dining room ideas include:

- Table runners
- Placemats/napkins
- Game table cover
- Folding chair cover
- Herb bags
- Hot pads/oven gloves
- Appliance covers
- Bun warmer

PATIO/GARDEN BANDANNA WEIGHTS

One colorful weight makes a paper-weight, two will make bookends, and four will hold down the corners of a picnic table cloth. Simply purchase a brightly colored bandanna, or make your own large square out of any fabric you choose. Tie around a rock, and it's ready to use (see Figure 8).

FLOWER POT COVERS

These look pretty and are simple to make. Use a tube of cardboard a little larger than the height and circumference of the flower pot as a form. The tube can be made from an oblong of cardboard glued or stapled together.

Cover the cardboard tube with one piece of fabric, turning 2 inches of fabric at each end to the inside of the tube (see Figure 9). Square covers can be made using cardboard boxes. To negotiate the corners on these, cut a small V at each corner (see Figure 10). Glue fabric overlap to the inside edges of the box or tube.

Figure 10

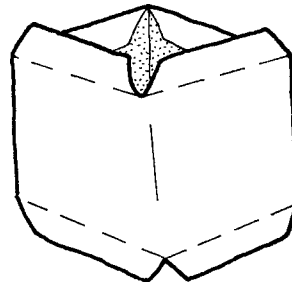

Other patio/garden ideas:

- Chair/table covers
- Gardener apron

PERSONAL USE

ULTRASUEDE® BUSINESS CARD CASE

To accommodate 2 x 3 1/2-inch business cards, cut one rectangle of Ultrasuede® 4 1/2 x 8 inches. Mark wrong side of fabric.

Fold short edges toward center, but do not let them meet. Leave a 1-inch space (see Figure 11).

Glue baste the edges in place with a 1/4-inch-wide film of glue stick. This water-soluble glue will hold the two layers of Ultrasuede® together and prevent slippage. Cover with a press cloth, and press with a warm, dry iron until flat.

Topstitch around entire piece with a 1/4-inch seam allowance along the two cut edges and 1/16-inch seam allowance along the two folded edges. Backstitch neatly to lock threads; clip threads closely.

Trim the 1/4-inch seam allowance close to the stitching.

Insert cards in both pockets and fold in half. This technique also can be used to make credit card holders, photograph carriers, checkbook covers, and passport covers.

Other personal use items include:

- Eyeglass case
- Bookmark

Contact: Linda Reece Adler, Extension Home Furnishings Specialist

Original authors: Bette Jo Dedic, Extension Clothing and Textiles Specialist, and Linda Reece, Extension Home Furnishings Specialist

Where trade names are used, no endorsement is intended, nor criticism implied of similar products not named.

Figure 11

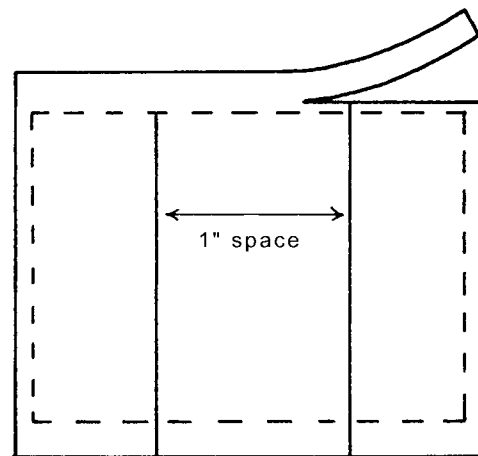

Marking/Transfer Pens

Permanent, wash-out, and air-soluble (vanishing) marking pens are available for use with light and dark fabrics. Iron-on transfer marking pens are also available. Always test pens on a fabric scrap before using.

Rotary Cutters and Mats

Rotary cutters are faster and easier to use than sewing shears or scissors. They will cut through up to eight layers at the same time. Mats are used to protect the surface underneath from the cutter. Different sizes of cutters and mats are available.

Fabric Glues/Adhesives

Several choices are available, including:

- Temporary fabric glue in stick form;
- Liquid fray preventer to stop fabric ravel; and
- Fabric glue to use in place of stitching.

Stabilizers

Use as a backing fabric to prevent puckering when finishing stitching is required, such as when monogramming. Different types and weights are available: soft, stiff, crisp, iron-on, tear-away, and wash-away plastic.

Decorative Accents

Look for many new types of products in pen or tube form to write, draw, or create interesting shapes and textures with paint, glitter, or plastic.